

REV	ECN. NO.	APP	DATE
A	EDIÇÃO INICIAL		

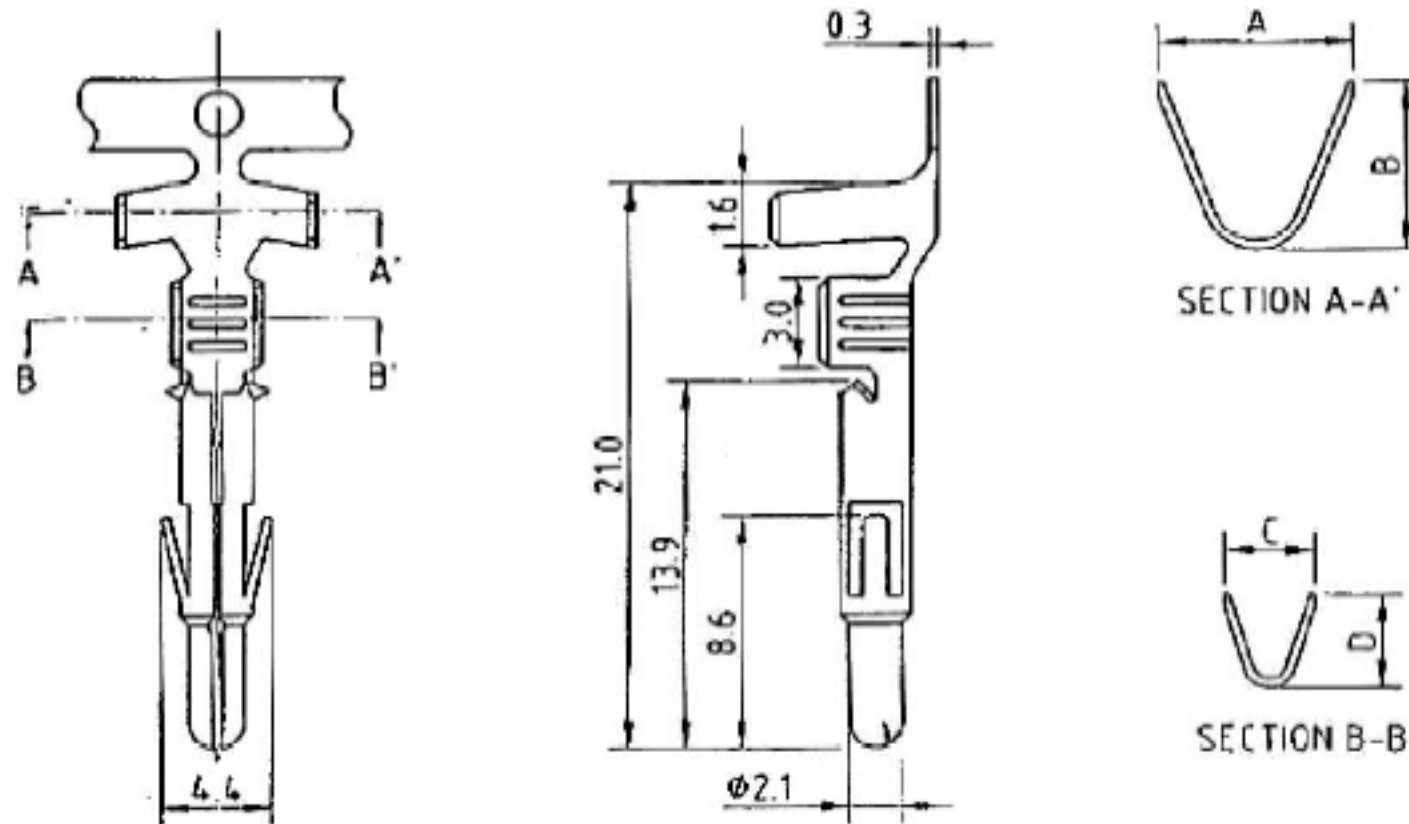

HOW TO ORDER: MX-6350-T-M-[]-[]-[]

- 1- Terminal Plating
 ()-Tin
 (D)-Gold Flash
 (C)-Selective Gold
 1- Wire Option
 (D)-18~22AWG
 (R)-16~20AWG
 (Q)-12~14AWG
 3- (R) RoHS Compliant

Contact Information

Wire Range	Insulation O.D.	DIM(mm)			
		A	B	C	D
AWG #18-#22	2.80mm(MAX.)	3.3	3.3	2.4	2.4
AWG #16-#20	3.00mm(MAX.)	4.0	4.5	3.5	3.2
AWG #12-#14	3.70mm(MAX.)	5.5	5.9	3.5	3.2

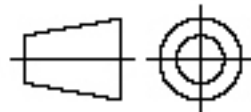
 MATRIX TECNOLOGIA IND. E COM. LTDA.			
UNIT mm	SCALE	TITLE 6,35mm TERMINAL MALE	DATE SEPTEMBER 2007
TOLERANCE: ±0.25			APP. BY
		MATL	CHK. BY
		DWG. NO.	DR. BY DINO