

REV	ECN. NO.	APP	DATE
A	EDIÇÃO INICIAL		
B	NOVO CÓDIGO		

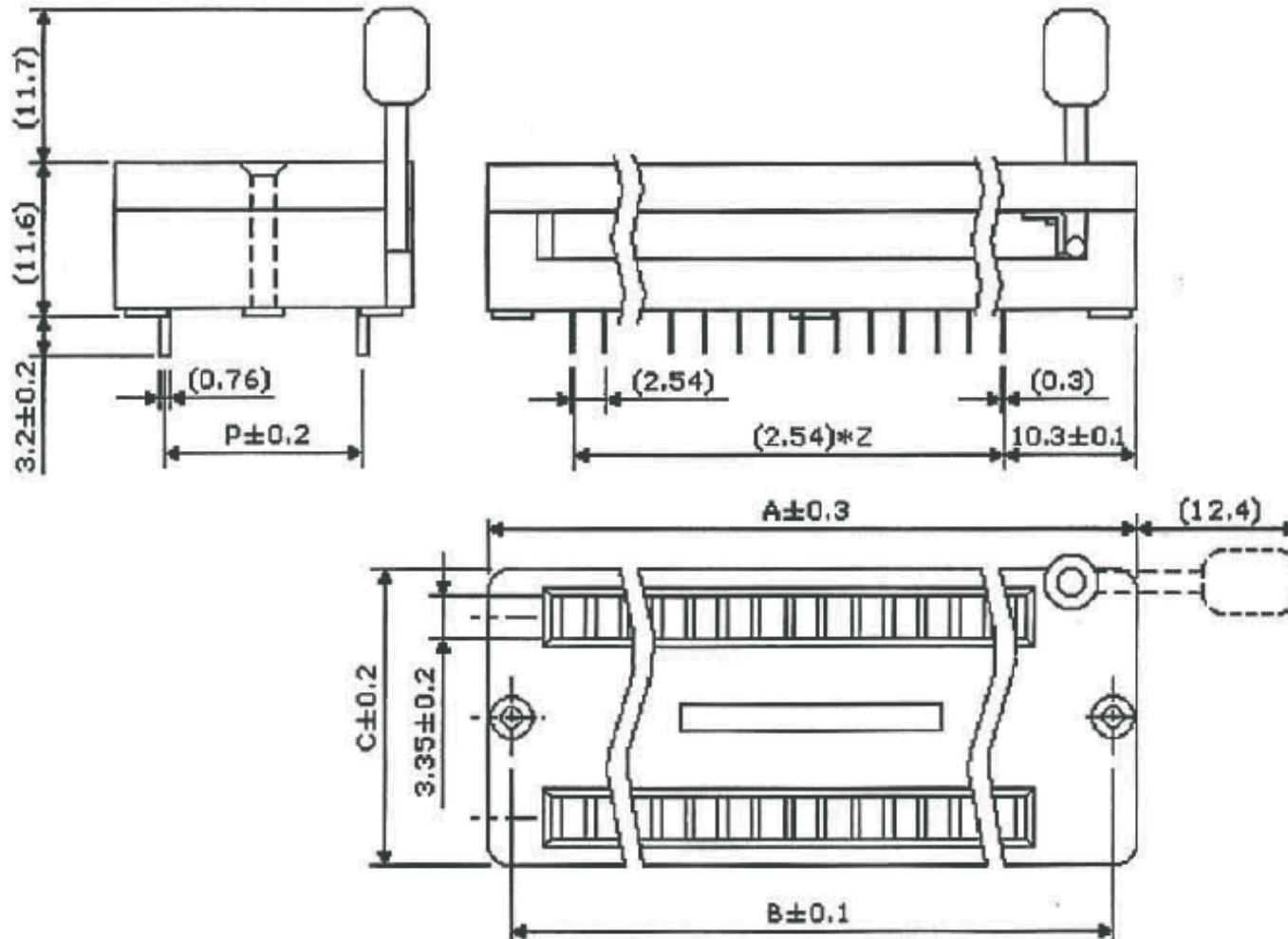

SPECIFICATIONS

ELECTRICAL

Contact Rating	50 VDC, 100mA
Contact Resistance	10 m ohms Max.
After Life Test	20 m ohms Max.
Insulation Resistance	100 Mohms Min.
Dielectric Strength	500 VDC Min. for 1 minute
Capacitance between adjacent pin	5pF Max.

MECHANICAL AND ENVIRONMENTAL

Temperature Rating: Operating	-40 to +85
Operating Life: 50,000 Cycles	(Without Load)
	25,000 Cycles (With Load)
Humidity: 95%RH, 40° C	for 96 Hrs.
Vibration: per MIL-STD-202F, METHOD 204D	
Solderability: After Flux	230±5° C For
	5±0.5 Seconds, 95% Coverage
Soldering Heat: 260±5°	for 5±1 seconds

HOW TO ORDER:

SZD[][]LR

1 2

- 1- Nr of Ways
See Table
2- Row Spacing
(I) 7,62
(D)15,24

LEADS	A	B	C	Z	P
24	45.3	40.9	14.9	11	7.62
24	45.3	40.9	22.9	11	15.24
28	50.4	46.0	22.9	13	15.24
32	55.5	51.1	22.9	15	15.24
40	65.6	61.2	22.9	19	15.24



MATRIX Tecnologia Ind. e Com. Ltda.

UNIT	SCALE	TITLE	DATE
mm		2.54mm Zero Insertion Pressure Socket	DECEMBER 2009
TOLERANCE: ±0.25			APP. BY
		MATL	CHK. BY
		DWG. NO.	DR. BY Felipe